

Since 1968

COMMAX
SmartHome & Security

User Manual

DOOR STATION DRC-2(4,6,8)ML/RF1, DRC-24XM(F)



<https://aros.kz>

www.commax.com

COMMAX Co.,Ltd.



- Thank you for purchasing COMMAX products.
- Please carefully read this User's Guide (in particular, precautions for safety) before using a product and follow instructions to use a product exactly.
- The company is not responsible for any safety accidents caused by abnormal operation of the product.

Contents

Safety Warning & Caution	2
1. Overview	4
2. How to use	5
3. Wiring	7
4. Installation	8
5. Part List	9
6. Specification	9

Safety Warning & Caution

Please follow the things described below in order to prevent any danger or property damage.

	<p>Warning It may cause a serious damage or injury if violated.</p>		<p>Prohibition.</p>
	<p>Caution It may cause a minor damage or injury if violated.</p>		<p>No disassembly</p>
			<p>No touch</p>
			<p>Must follow strictly.</p>
			<p>Shows plugging out the power cord without an exception</p>
			<p>Shows the warning and caution for an electric shock.</p>
			<p>Shows the warning and caution for a fire.</p>

Warning

Power & Installation

<p>Please don't use several products at the same time on one power socket. · It may cause a fire due to an abnormal overheating.</p> <p> </p> <p>Prohibition Fire</p>	<p>Please don't bend the power cable excessively or it may cause an electric shock. · fire when using a damaged power cable.</p> <p> </p> <p>Prohibition Electric shock Fire</p>	<p>Please don't handle the power cable with a wet hand. · It may cause an electric shock.</p> <p> </p> <p>Prohibition Fire</p>	<p>Please plug out the power cable from the socket when not using it for a long period of time. · It may shorten the product lifespan or cause a fire.</p> <p> </p> <p>Request Fire</p>
<p>Please don't install the product in the place where there is much oil, smoke or humidity. · It may cause an electric shock or fire.</p> <p> </p> <p>Prohibition Electric shock Fire</p>	<p>Please don't install the product with the lightning and thunder. · It may cause an electric shock or fire.</p> <p> </p> <p>Prohibition Electric shock Fire</p>	<p>Please don't use and connect this product with other products with different rated voltage · It may cause a disorder or fire.</p> <p> </p> <p>Prohibition Fire</p>	<p>When installing the product that generates heat, please install the product away from the wall (10cm) for the ventilation. · It may cause a fire due to the increased internal temperature.</p> <p> </p> <p>Prohibition Fire</p>

⚠ Warning

Cleaning & Use

Please don't disassemble, repair or rebuild this product arbitrarily (please contact the service center if a repair is needed).

- It may cause an electric shock or fire.

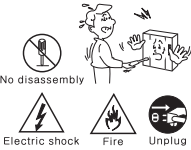

If an abnormal sound, burning smell or smoke is coming out of the product, please plug out the power cable and contact a service center.

- It may cause an electric shock or fire.

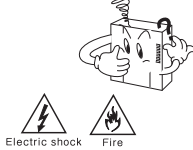

Please don't insert any metallic or burnable materials into the ventilation hole.

- It may cause an electric shock or fire.

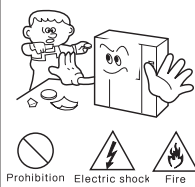

Please use only the designated batteries for the products of using DC power.

- It may cause an electric shock or fire.

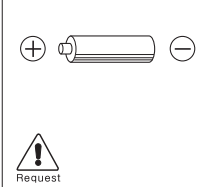

⚠ Caution

Power & Installation

Please plug the power cable firmly into the inner end

- It may cause a fire.

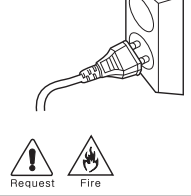

Please hold the plug tightly when unplugging the power cable (a part of the copper wire may be disconnected if the grabbing is only made on the cord when pulling out the cable).

- It may cause an electric shock or fire

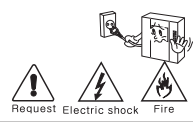

When connecting the power cables after cutting the cable, please install the product with power off

- It may cause an electric shock or fire

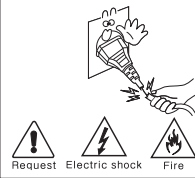

When installing the product, please fix it firmly while using the wall-mounting unit and screws.

- It may cause an injury from the falling object.

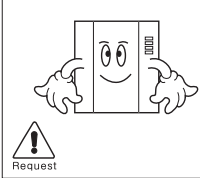

Please be careful when using an AC circuit breaker since there is a possibility of an electric shock.

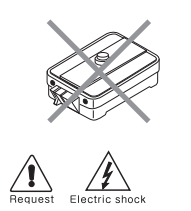

Please check the use voltage and current for the DC-only products and use the appropriate rectifier.

- It may cause a fire.



Please avoid direct rays of the sun or heating devices at a time of installation.

- It may cause a fire.



Please don't install the product on an unstable place or small support board.

- It may cause an injury if it falls down while in use.

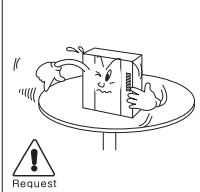

Cleaning & Use

When cleaning the product, please rub it with a soft and dry cloth after plugging out the power cable. (Please don't use any chemical products such as wax, benzene, alcohol or cleanser.)

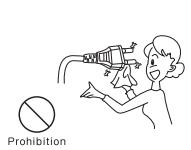

Please don't drop the product on the ground and don't apply a shock.

- It may cause a failure.



Please use the designated connection cable within the maximum calling distance designated for the product

- It may reduce the product performance.

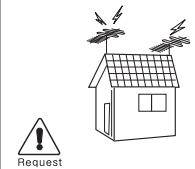

1. Overview

(1) DRC-2ML/RF1

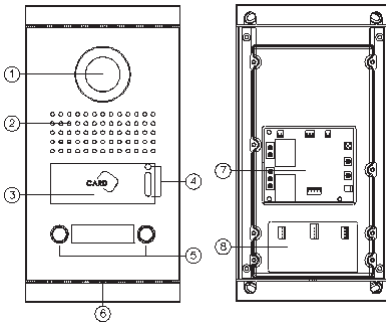

(2) DRC-4ML/RF1

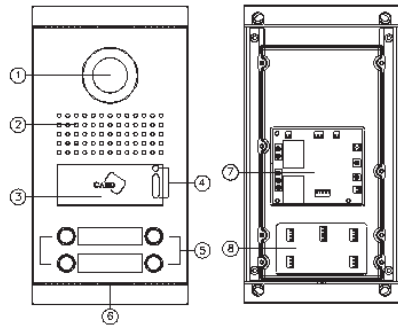

(3) DRC-6ML/RF1

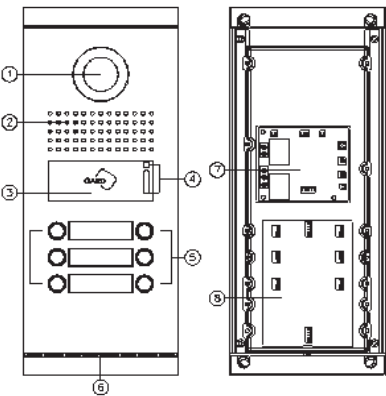

(4) DRC-8ML/RF1

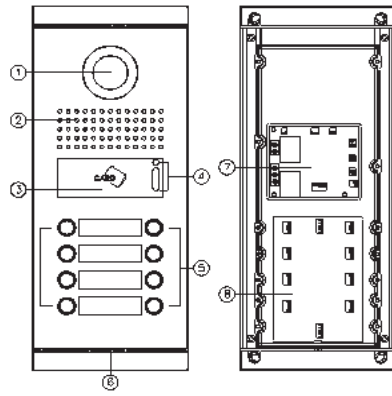

No.	Contents	No.	Contents
1	Camera	5	Household call button
2	Speaker	6	Microphone
3	125KHz or 13.56MHz RF reader	7	Wiring 1 (Refer to '3. Wiring')
4	CDS sensor & LED light	8	Wiring 2 (Refer to '3. Wiring')

2. How to use

2-1 Function

- 1.The power supply of this product is DC12V.
- 2.If the household videophone is answered when you call from this door camera(entrance), you can talk with household.
- 3.Please note that 3-way communication is possible when another user turn on the monitor when you are talking with visitor at the entrance.
- 4.Please note that 3-way communication is possible when you call a house and then call to other house in a row.
- 5.This product supports 2 ports for OPEN contact so that CDV-70KR3/70AR3 videophone can be connected.
- 6.If you want to open the door using a RF card key, please tag it to CARD point.
- 7.You cannot use a RF card, when you talk with household or any household is monitoring.
- 8.Extension panel (DRC-24XM(F)) can be connected up to 1 unit.

2-2 How to register/delete RF card

* Button type

Button 1 : to register RF master card only for registration of other RF cards
Button 2 : to register RF master card only for deletion of other RF cards

1. How to register Master Card

1) Master card for Registration

- (1) LED slowly flickers with beep sound on pressing button 1.
- (2) Tag the master card for registration on LED flickering.
- (3) If registered normally, LED flickering and beep sound stops.

2) Master card for Deletion

- (1) LED flickers fast with beep bound on pressing button 2.
- (2) Tag the master card for deletion on LED flickering.
- (3) If registered normally, LED flickering and beep sound stops.

- * Remark : Master card can be registered both registration/deletion purpose.
(1card for each purpose only) In case of new mater card registration, the previous master card information will be deleted and new card should be registered.

2. Door release card registration/deletion

1) Card registration

- (1) On tagging the master card for registration, LED slowly flickers with beep sound.
(Entering registration mode)
- (2) Beep sound comes out when door release card is tagged.
- (3) In case more than 1 cards have to be registered, repeat above (2) procedure.
- (4) In case you finish registration, please tag the master card or registered door release card.

2) Individual Card deletion

- (1) LED flickers fast on tagging master card for deletion.
(Entering Pre-Deletion mode).
- (2) Press button 3. Then beep sound comes out.
(Entering Individual deletion mode)
- (3) In case more than 1 cards have to be deleted, repeat above (2) procedure.
- (4) In case you finish deletion, please tag the master card.

3) All cards deletion

- (1) Tagging the master card (for deletion) 3 times in 4 seconds, LED flickers fast with beep sound. (Entering Pre-Deletion mode).
- (2) If you tag master card for deletion once more in 4 seconds, the beep sound stops and all card information is processed.
- (3) When all card information is deleted, LED light flickering will be stopped after beep sound.

* Remark : Maximum 2,046 cards can be registered. (including 2 master cards)

Do not turn off the device until all cards deletion process is completed.

* Precautions

- Other than the RF card provided by COMMAX, the recognition sensitivity may be degraded or it may not work.
(Please use the RF card provided by COMMAX because it may cause security problems.)

3. Wiring

(1) DRC-2ML/RF1

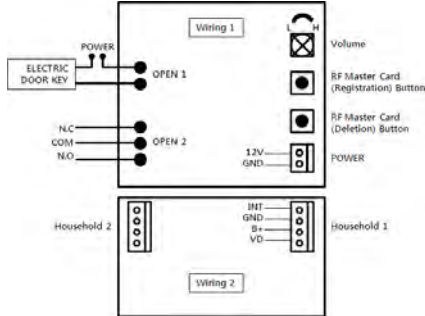

(2) DRC-4ML/RF1

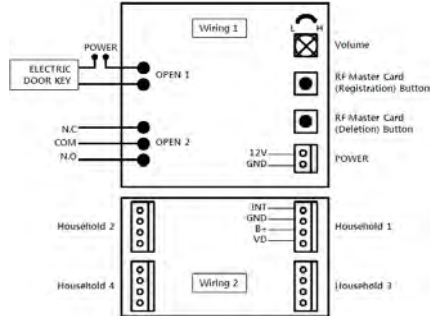

(3) DRC-6ML/RF1

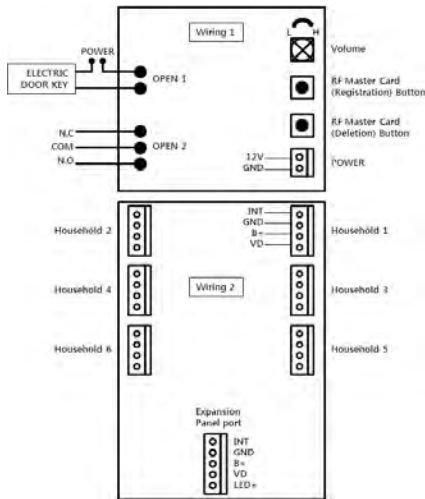

(4) DRC-8ML/RF1

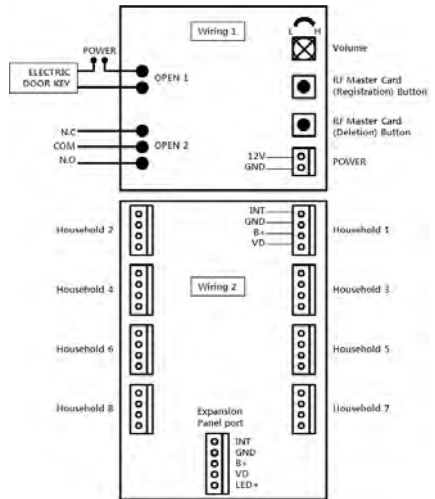

* Refer

- DRC-2ML/RF1 and DRC-4ML/RF1 are cannot connect to an expansion panel(DRC-24XM(F)).

4. Installation

(1) DRC-2ML/RF1

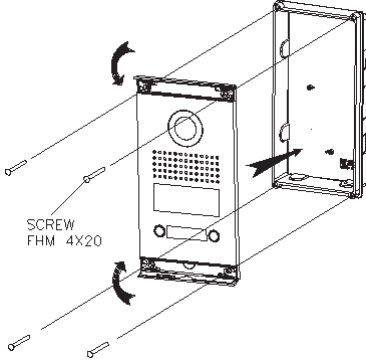

(2) DRC-4ML/RF1

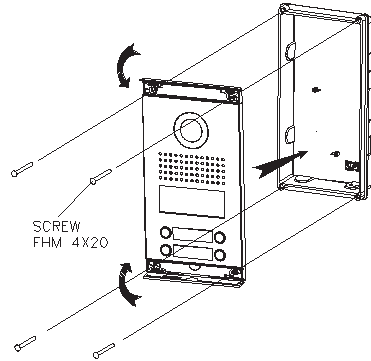

(3) DRC-6ML/RF1

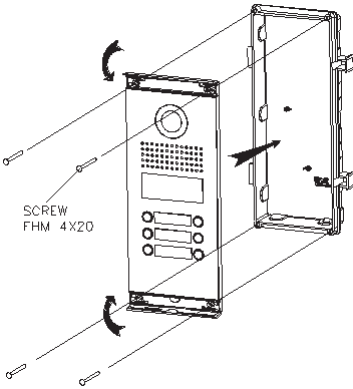

(4) DRC-8ML/RF1

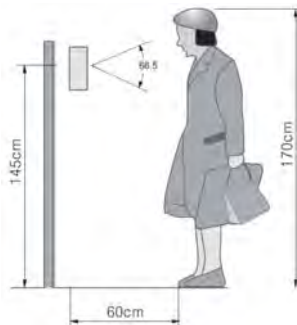
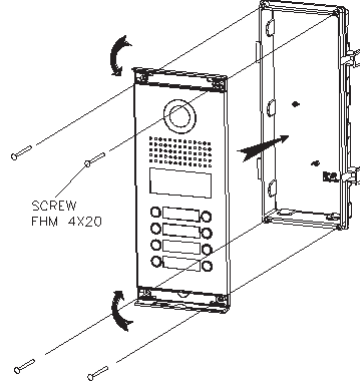

5. Part List

Item	Description	Qty
CONN. 4Px300	Wiring Connector(DRC-2ML/RF1)	2
	Wiring Connector(DRC-4ML/RF1)	4
	Wiring Connector(DRC-6ML/RF1)	6
	Wiring Connector(DRC-8ML/RF1)	8
SCREW FHM 4x20	Bracket + Flush Mount Bracket	4
ADAPTER	12V / 1A Adapter	1
POWER CORD	Adpater Power Cord	1
MANUAL	User Manual	1

6. Specification

Model No.	DRC-2(4,6,8)ML/RF1		
Power source	DC12V, 1A		
Wiring	4 Wires(Polarity)		
Communication	Hands-free(Duplex)		
Min. Lux.	0.1Lux(UP TO 300mm From the Camera)		
Light	White LED(3pie) 2EA Built-In		
Camera Angle	H : 82° , V : 66.5° , D : 130°		
Camera Module	C-MOS		
RF Module	13.56MHz		
Temperature	-20°C(tested up to -40°C) ~ +50°C		
Dimension(mm)	DRC-2(4)ML/RF1 : 130(W)× 246(H)× 50(D) DRC-6(8)ML/RF1 : 130(W)× 315(H)× 50(D)		
Communication Distance	Diameter	φ 0.5	φ 0.65
	Distance	30m	50m